

# Touch Panel Switch



CT-LCZW5025-MH

CT-LCZW5026-MH

CT-LCZW5027-MH

## Introduction

Touch Panel Switch is mainly used for lighting control and suitable for general lights as well as energy saving lights. This Z-Wave product is compatible with Hioth system which supports local and remote status check and control as well as combines with other devices to do more settings such as scenarios, linkage control.

The touch panel switch has a beautiful and concise appearance and for the US regulatory dimension and can be directly replaced the ordinary wall switch to reduce the cost and time of rewiring.

## Technical Information

- Local touch panel and mobile terminal control
- Replace the traditional switch, retain the original lights
- Combined with other devices to set more controls

## Specifications

- Radio protocol: Z-Wave
- Radio Frequency: 908.42MHz
- Power supply: 85 V-260V AC
- Maximum load: maximum load 1 road, every road load 5A
- Installation method: wall-mounted (standard American box installation)
- Dimension: 120mm × 75mm × 38mm

## Installation Instructions

### PRODUCT INSTALLATION

#### CAUTION:

Cut off power supply at circuit breaker or fuse before installation to avoid fire or shock! Neutral and live wire are required to put into the bottom box.

- 1) As shown in Fig.1, using the screwdriver to pry the gaps on the side of the switch, then open the panel.

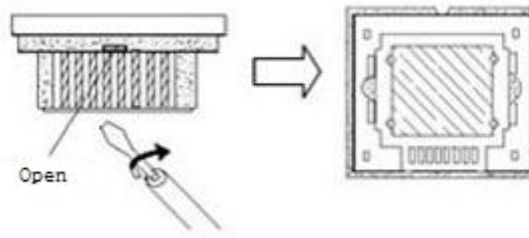

Fig.1

- 2) Using both hands to hold the switch panel and forcibly push up to remove the switch panel.
- 3) Follow the Fig.2 diagram to start wiring:

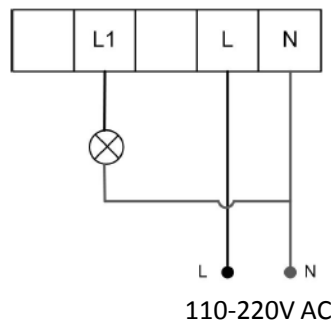

Fig.2

**Notes for the diagram:**

**L**- terminal for live lead

**N**- terminal for neutral lead

**L<sub>1</sub>**-output terminal of load (controlling connected lighting device, or other load)

**INSTALL THE SWITCH BASE**

As shown in Fig.3, install the touch switch inside the wall box after wiring, then screw up to make it fixed on the wall. Put the base to the wall as well as cover and press the touch panel.

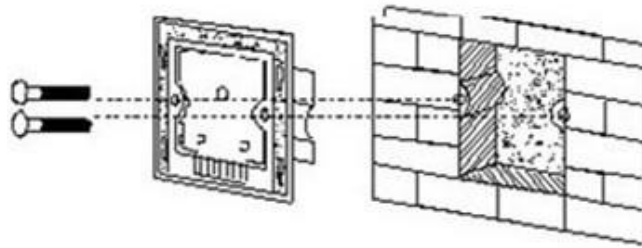

Fig.3

**Operation**

**NETWORK ENTRY**

- 1) Please follow the below menu order on APP to find the network join interface:

Log in > Menu bar > Device Management > Add device

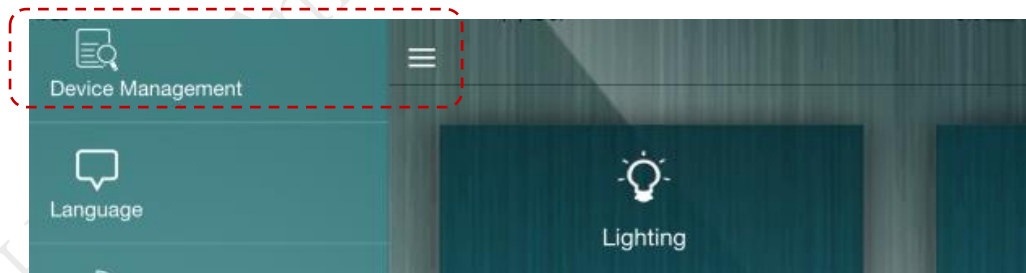

- 2) Connect the power supply, and make sure that device in a state of "No node ID".
- 3) Press and hold any key on the panel for 8 seconds (INDICATION LED on the panel will turn green.).
- 4) Choose "Z-Wave" to enter the Network Inclusion mode on the APP, then click "✓".



- 5) When prompt a message “Request Access Success”, please go to the device list interface, and refresh the device list, the device will be displayed.

### **NETWORK KICKOUT**

- 1) Make sure the device is connected to the power supply.
- 2) Remove the device on the APP, then click "Save".
- 3) Press and hold any key on the panel for 8 seconds (the LED on the panel will turn orange.).
- 4) If network kickout is successful, switch will turn off, please go to the device list interface, and refresh the device list, the device will not be displayed.
- 5) If the device can still be displayed (network exclusion failed), repeat steps 2-5.

**If the device:**

**Online: directly perform steps 1-5;**

**Offline: disconnect the device first and then perform steps 1-5.**

### **Safety Notice**

- A qualified electrician with the understanding of wiring diagrams and knowledge of electrical safety should complete installation following the instructions.
- Before installation, please confirm the real voltage complying with the device’s specification. Cut off any power supply to secure the safety of people and device.
- During installation, protect the device from any physical damage by dropping or bumping. If happened, please contact the supplier for maintenance.
- Keep the device away from acid-base and other corrosive solids to avoid damage.
- Avoid overexertion during operation, to protect device from mechanical damage.
- Read all instructions and documentation and save for future reference.